

# Boiler Installation and Maintenance Manual

## Condensing Gas Boiler SB735 Series

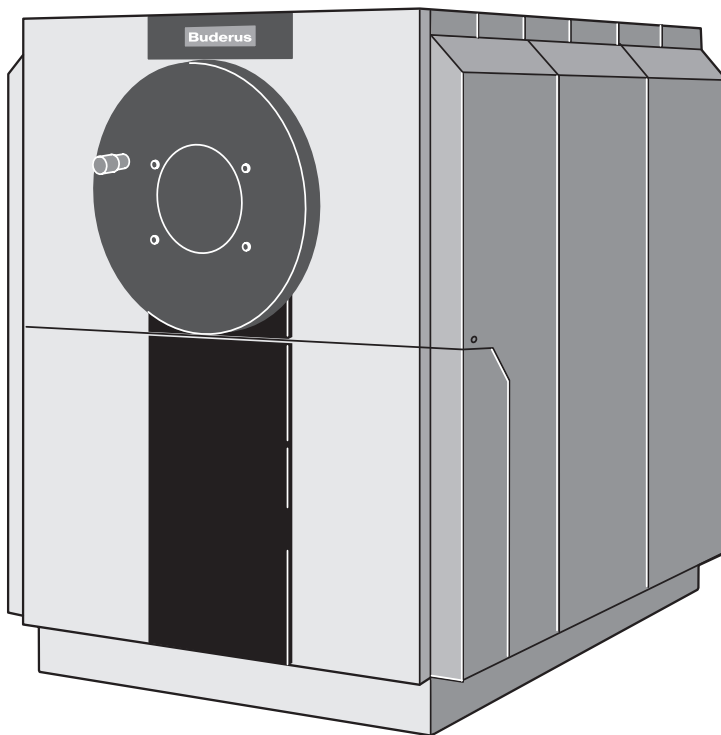

Buderus



This equipment conforms to the following European and US requirements:

- 90/396/EWG European gas fired guidelines  
Standards: EN 677, EN 303-1, EN 303-3, DIN 4702-6
- 92/42/EWG European efficiency guidelines
- 73/23/EWG European low voltage guidelines
- 89/336/EWG EMV- European electromechanical code guidelines
- 97/23/EG European pressure vessel guidelines  
Standard: TRD 702
- ASME Boiler and Vessel Pressure Code

Confirmation regarding conformity with respect to these guidelines can be obtained upon request from Buderus Hydronic Systems, Inc.

## Technical Changes!

Buderus Hydronic Systems, Inc. reserves the right to this make changes due to continued technological and engineering improvements.

## Updating Technical Informations

Please contact us if you have suggestions for improving this manual or when you have noticed incorrect information.

## Manufacturers Address:

Buderus Hydronic Systems, Inc.  
50 Wentworth Ave

Londonderry, New Hampshire 03053

[www.buderus.net](http://www.buderus.net)

**Document number: 6302 2320**

**Issue: 10/2003**

# TABLE OF CONTENTS

<b>1</b>	<b>General Information</b>	<b>4</b>
1.1	General Information.	4
1.2	Regulations and Guidelines	4
1.3	Hydrostatic test	4
<b>2</b>	<b>Packaging and Components</b>	<b>5</b>
<b>3</b>	<b>Technical Data, Dimensions and Water Connections</b>	<b>6</b>
<b>4</b>	<b>Boiler Installation</b>	<b>7</b>
<b>5</b>	<b>Anti-Vibration Supports</b>	<b>8</b>
<b>6</b>	<b>Boiler Assembly</b>	<b>9</b>
6.1	Installation of the Thermal Insulation and Jacket Panels.	9
6.2	Boiler Jacket - Pack A	11
6.3	Boiler Jacket - Pack B	15
6.4	Installation of the Control Panel and Sensor Well	16
6.5	Burner Door and Burner	18
6.6	Boiler Jacket - Top Covers	19
6.7	Rating Tag Plate.	19
6.8	Boiler Jacket - Pack C	20
6.9	Venting System	21
6.10	Neutralization Equipment and Water Controls Installation.	23
<b>7</b>	<b>Placing the Boiler in Operation</b>	<b>24</b>
<b>8</b>	<b>Maintenance</b>	<b>25</b>
8.1	General Information.	25
8.2	Cleaning of the Boiler.	25
<b>9</b>	<b>Check List</b>	<b>27</b>

# 1 General Information

## 1.1 General Information

This Boiler Installation and Maintenance Manual contains important information regarding proper and safe assembly, start-up and operating and maintenance procedures for the SB735 series boilers!

The assembly and maintenance instructions are designed for the installing contractor, who, due to vocational training, is familiar, knowledgeable and experienced in heating system and gas piping installations.

## 1.2 Regulations and Guidelines

This document also makes reference to additional accessories that may be used in conjunction with the SB735 boilers. Observe the proper installation instructions when installing these accessories.

The installation must conform to the requirements of the authority having jurisdiction or, in absence of such requirements, to the latest edition of the National Fuel Code, ANSI Z223.1.



**DANGER!**

due to combustion products.

Route flue gases via venting system to the atmosphere. Use only approved venting materials.

Have the system inspected by an authorized person prior to start-up. Only start-up the system after approval.

Check system for leaks.

The Buderus SB735 boiler is a condensing boiler suitable for firing with natural gas or propane only.

The installation of a low water cut-off and pressure relief valve must be based on local code requirements. Please install these components per manufacturer's instructions and per detail on page 23.



**NOTICE**

To avoid build-up of debris inside the heat exchanger of the boiler, it is recommended to install a filter on the boiler return connection(s).

## 1.3 Hydrostatic test

Perform a hydrostatic test. The test pressure should be 1.5 times the actual operating pressure in the heating system, however a minimum of 14 psi.



**NOTICE!**

Observe the listed boiler output ratings as shown on the boiler rating plate.

### Maximum Temperature and Pressure Ratings:

Maximum Temperature and Pressure Ratings		
Maximum Supply Temperature:		210 °F
Allowed System Pressure (Models)	790	43.5 psi
	970	43.5 psi
	1200	43.5 psi
Maximum Time constant:		
- Manual Reset High Limit		40 sec
- Adjustable High Limit		40 sec

Table. 1 Maximum Temperature and Pressure Ratings

### Permissible Fuels:

Logano SB735: Fuel Natural Gas or L.P

Please observe the guidelines of the gas supply company!

## 2 Packaging and Components

The complete product is shipped in the following components:

- Boiler vessel, bolted on transport woods
- Supply manifold, packaged with hydronic control package
- Technical documentation, secured to the boiler
- VE insulation rings for burner and PVC condensate drain (Siphon) secured to the boiler
- Boiler jacket panels and installation components, packaged in a wooden crate and cardboard. The assembly components are located in Pack A.
- The insulation blankets are packaged in 2 plastic bags.
- A sound attenuating boiler base is supplied standard with the SB735/1200 model.
- Electronic control panel, in cardboard box (optional).
- A condensate neutralization package can be ordered separately.
- Hydronic control package, consisting of aquastat, low water cut-off, relief valve and temperature pressure gauge (when ordered from Buderus).
- Gas burner and gas train components, if ordered from Buderus.
- Pre-cut burner mounting plate, if ordered from Buderus.

Above mentioned components may differ slightly based on the particular boiler model.

## 3 Technical Data, Dimensions and Water Connections

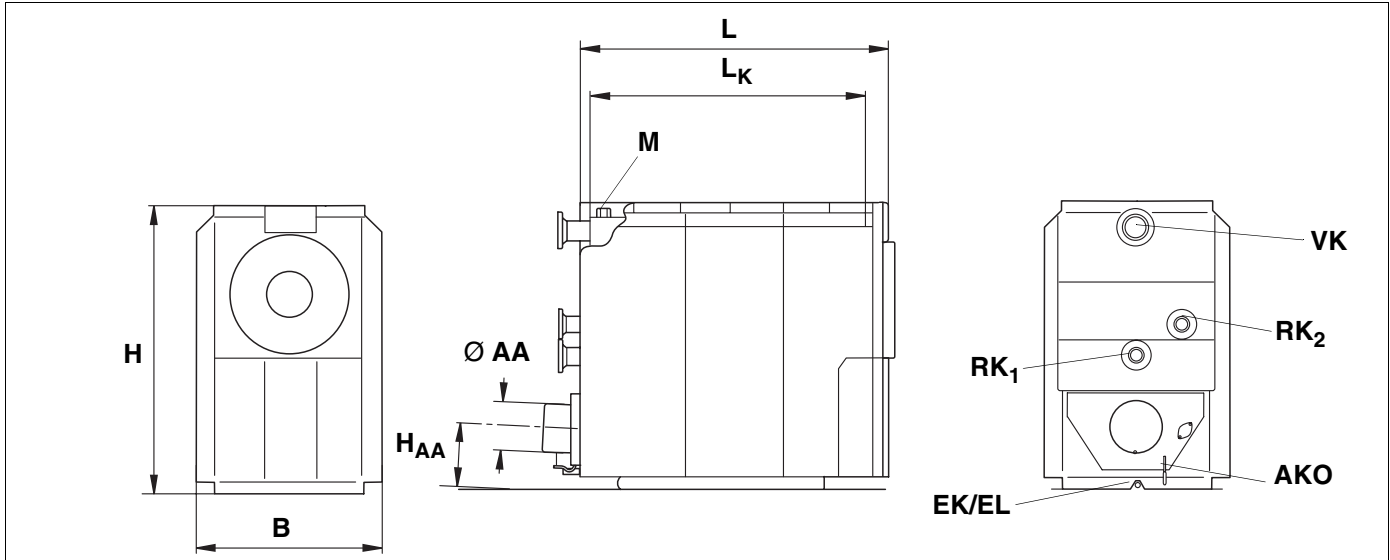

Fig. 1 Technical Data, Dimensions and Water Connections

VK = Boiler Supply Connection

RK1 = Low Temperature Return Connection

RK2 = High Temperature Return Connection

H\* = Boiler Height with Logamatic 2107/2109=H+6 inch

AKO = Condensate Drain

EK = Water Feed

EL = Boiler Drain

M = Sensing Port for Temperature Sensor

Ø AA = Vent Pipe Diameter

Boiler Model			790	970	1200
Max. Input		[MBH]	2751	3378	4179
Max. Output		[MBH]	2605	3251	4079
IBR Net		[MBH]	2265	2827	3547
Thermal Efficiency		[%]	96.9	96.3	97.6
Combustion Efficiency		[%]	94.7	95.6	96.5
Length	L	Inch	91 ½	108 ¼	108 ¼
Length	L <sub>K</sub>	Inch	75 ½	92	92
Height	H	Inch	81 ¼	81 ¼	81 ¼
Width	B	Inch	54	54	54
Boiler Widthless Jacket		Inch	44 ¼	44 ¼	46 ¼
Vent Connection-Ø inside	Ø AA	Inch	14	14	14
Vent Height	H <sub>AA</sub>	Inch	19	19	19
Weight		Lbs.	4330	5441	5534
Boiler supply	VK	Inch	4	5	5
1. First Return Connection	RK <sub>1</sub>	Inch	4	5	5
2. Second Return Connection	RK <sub>2</sub>	Inch	3	4	4
Boiler Drain/Water Feed	EK/EL	Inch	1½	1½	1½

Table. 2 Technical Data, Dimensions and Water Connections

## 4 Boiler Installation

It is required to have a floor drain available near the boiler.

It is recommended to place the boiler on solid foundation of 2" to 4" height. Use dimension B and L (Table 3) to size this foundation.

The supporting floor must be level and of sufficient strength.

Observe the indicated side clearances when placing the boiler (Fig. 2). Dimensions shown indicate minimum clearances to combustibles or space needed to swing open burner door.

Place the boiler horizontally on the supporting foundation.

Boiler Model	L [Inch]	BK [Inch]	A [Inch]
790	91	43 ¾	98"(43")*
970	107 ½	43 ¾	98"(43")*
1200	107 ½	46	98"(43")*

Table 3 Minimum Boiler Pad

Please observe the burner length  $L_{Br}$  with respect to the front clearance.

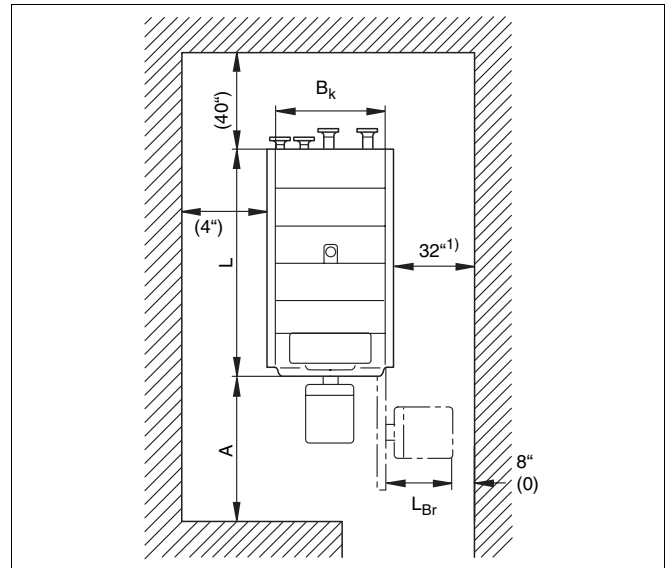

Fig. 2 Clearance dimensions for SB735 boilers



**NOTICE!**

Make sure to install the base supplied with the SB735/1200.

## 5 Anti-Vibration Supports

- Anti-vibration supports are standard equipment on the SB735/1200 model; they can be ordered separately for the other models.
- Insert the longer part of the longitudinal anti-vibration bracket (Fig. 3, **Item. 4**) from the front and the shorter part (Fig. 3, **Item. 3**) from the rear into the channel sections (Fig. 3, **Item. 2**).
- Position both rails of the anti-vibration boiler support, in accordance with dimensions shown in Table 4, on the floor where the boiler is to be installed.



### NOTICE!

Prepare the foundation, where the anti-vibration supports are to be located, with a smooth trowel of  $\pm 1/8$ " per linear foot and with a slight rise to the back. This ensures an even load distribution over the longitudinal anti-vibration brackets, and adequate boiler ventilation.

- Position, align and place the boiler on the supports. The boiler support should be flush with the boiler back wall. The end-stop plates (Fig. 3, **Item. 1**) should contact the channel section of the boiler.

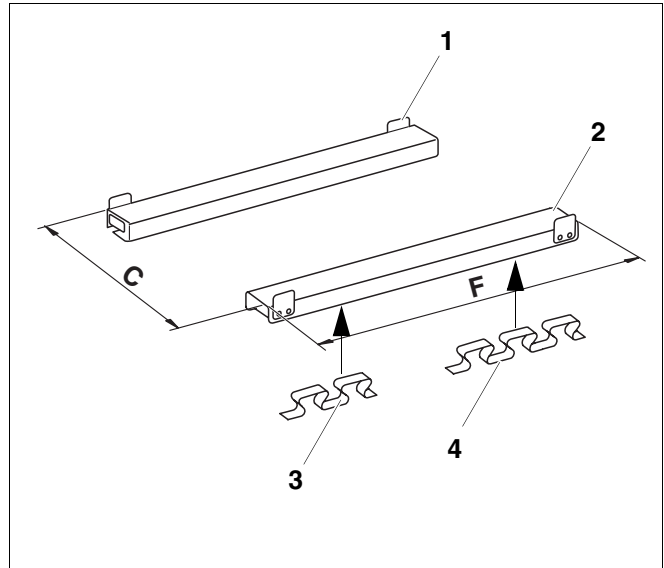

Fig. 3 Anti-vibration support

- Item. 1: End-stop plates
- Item. 2: Channel section
- Item. 3: Short anti-vibration bracket
- Item. 4: Long anti-vibration bracket

Boiler Type	Boiler-Model	Length F [Inch]	Distance C [Inch]
SB735	1200 <sup>1)</sup>	90	46
	970 <sup>2)</sup>	90	43 <sup>3</sup> / <sub>4</sub>
	790 <sup>2)</sup>	73 <sup>1</sup> / <sub>2</sub>	44

Table. 4 Support dimensions

- <sup>1)</sup> Standard delivery
- <sup>2)</sup> Accessories



## 6 Boiler Assembly



### NOTICE!

Make sure, that when fitting the front thermal insulation, the burner door of the combustion chamber is closed, to prevent damage to the stainless steel combustion chamber from welding or grinding activities.

Order of installation:

1. Thermal insulation/Pack A
2. Pack B
3. Pack C

### 6.1 Installation of the Thermal Insulation and Jacket Panels



### NOTICE!

Ensure that the fabric is on the outside when fitting the insulation blankets.

- Position the insulation blankets for the boiler body so that the cut-outs are located over the cross brackets plates (Fig. 5, **Item. 1**).



### NOTICE!

Position the narrow insulation blanket for boiler model 790 at the rear, and note the drain cut-outs.



### NOTICE!

Note the cut-outs for the low water indicator and the cross bracket holder (Fig. 7, **Item. 1 + 5**)!

- Position the front insulation blanket with its cut-out, over the cross bracket holder.
- Tuck the insulation blanket in underneath the boiler (Fig. 5).

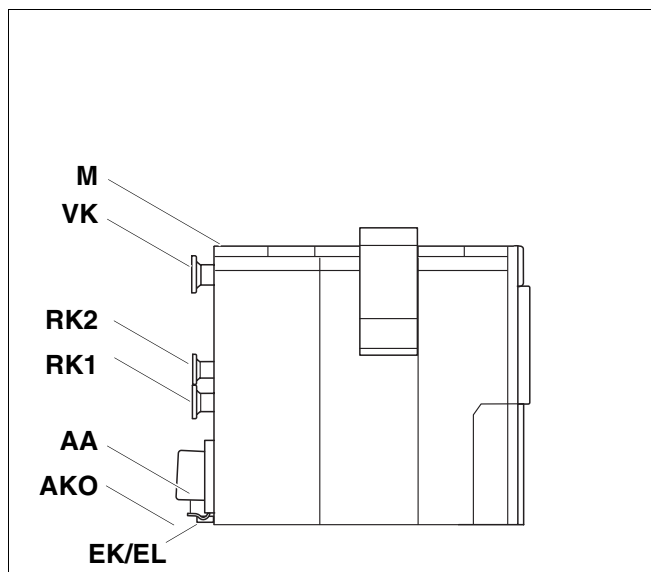

Fig. 4 Connections

- M = Sensing port for temperature sensor
- VK = Boiler supply and relief valve connection
- RK2 = High temperature boiler return
- RK1 = Low temperature boiler return
- AA = Vent connection
- AKO = Condensate drain
- EK/EL = Water feed/boiler drain

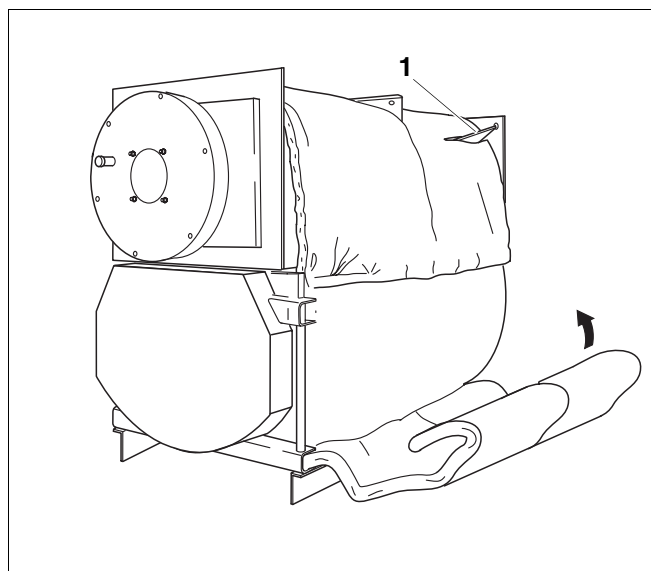

Fig. 5 Insulation blanket

- Overlap the insulation blankets on the side and wrap around the boiler body, then fasten with 8 clips.
- Unscrew four hexagon bolts (Fig. 6, **Item. 1**) from the right side of the boiler door (Fig. 7, **Item. 1**) and four from the left side.

**DANGER OF INJURY!**

through falling parts.

Ensure that the hinge bolts (Fig. 21, **Item. 1**) are in the boiler door before opening it.

**NOTICE!**

The recesses (Fig. 6, **Item. 2**) in the boiler door (2 on the left and 2 on the right side) have been provided for lifting with a crane or hoist, for example for the complete removal of the door.

- Open the burner door (Fig. 7, **Item. 1**)
- Place the insulation blanket with round cut-out (Fig. 7, **Item. 2**), with its wide edge facing upwards, on the left front of the boiler body (wide edge up) and secure with four clips (2 left, 2 right) on the surrounding thermal insulation.

**CAUTION!**

Ensure that the wide edge is at the top at the hinge bolts!

- Close the burner door and re-secure with eight hexagon bolts.
- Position the thermal insulation strip (Fig. 7, **Item. 3**) laminated on the front of the reversing door.
- Position the thermal insulation strips (Fig. 7, **Item. 4**) for the reversing door from below around the side of the reversing door and secure with two clips.

**NOTICE!**

Observe the hinge bolt cut-outs!

- Locate the rear side thermal insulation (Fig. 8, **Item. 2**) in accordance with the cut-outs on the rear side of the boiler and secure with six clips (Fig. 8, **Item. 1, 3** left and 3 right) on the surrounding thermal insulation (Fig. 8, **Item. 3**).

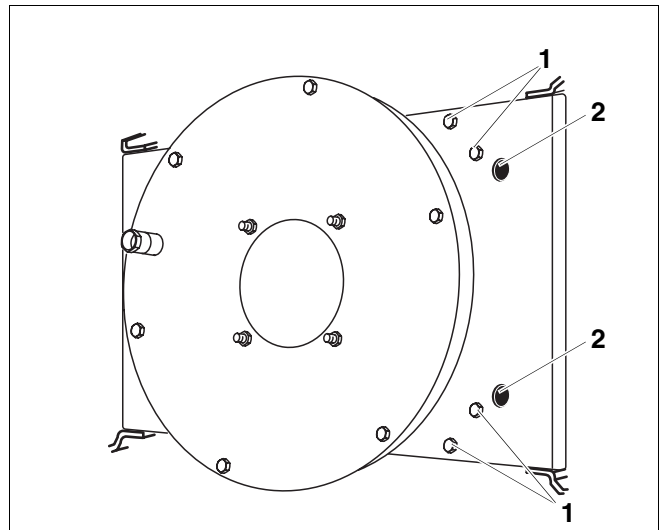

Fig. 6 Screws for opening the burner door

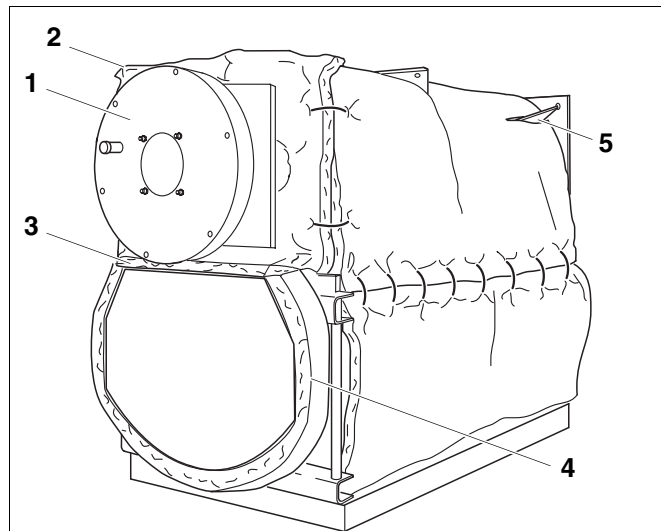

Fig. 7 Burner door insulation blanket

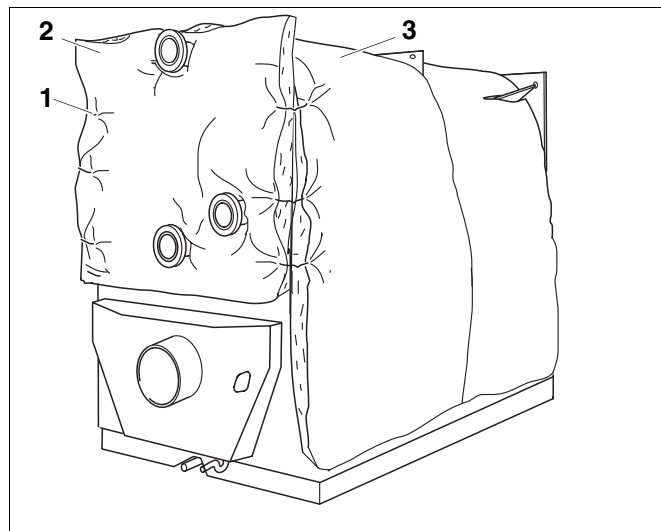

Fig. 8 Rear side insulation blanket

## 6.2 Boiler Jacket - Pack A

- Locate the front cross bracket (trapezoidal cut-out down) with its two top holes on the threaded studs and secure with nuts (Fig. 9).
- Locate the rear cross bracket (V-shaped cut-out down) with its two top holes on the threaded studs and secure with nuts (Fig. 9).



### NOTICE!

The edge of the cross bracket must point outwards (Fig. 9).

- Insert the insulation blanket from the burner door (Fig. 7, **Item. 2**) and the rear side (Fig. 8, **Item. 2**) into the upper edge and the front and rear cross bracket.
- Lightly insert two screws M8 x 80 (Fig. 10, **Item. 3**) from the top into the central cross bracket (Fig. 10, **Item. 1**).
- Secure the central gross bracket (Fig. 10, **Item. 1**) at the top to the fixing bracket using two bolts, washers and nuts (Fig. 10, **Item. 2**).



### NOTICE!

Ensure that the edge of the central cross bracket (Fig. 10, **Item. 1**) points forward.

- Lightly secure the central cross bracket front (Fig. 9, **Item. 1**) on the left and the right side using two bolts and washers.



### NOTICE!

Initially secure the central cross bracket (Fig. 9, **Item. 1**) only lightly. Tighten the cross brackets after they have been aligned and secured to the side wall closest to the front.

- Push the strain relief (Fig. 10, **Item. 4**) on the hinge side of the burner door into the cross bracket.
- Secure the strain relief with two bolts (Fig. 10).

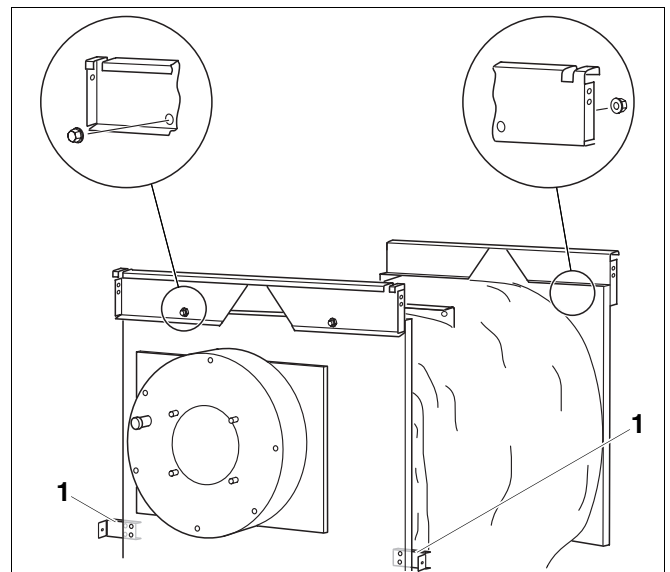

Fig. 9 Cross brackets

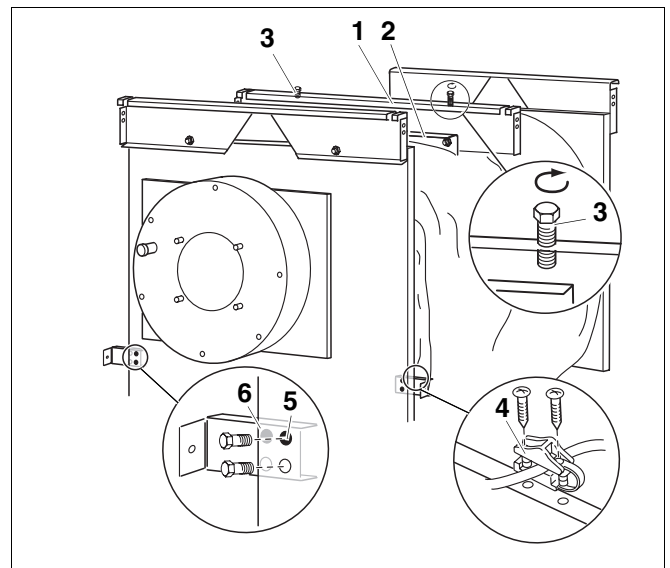

Fig. 10 Strain relief

Item. 1: Central cross bracket

Item. 2: Fixing bracket

Item. 3: M8 x 80 bolts

Item. 4: Strain relief

Item. 5: Bolt location central cross bracket for boiler models 790 and 970

Item. 6: Bolt location central cross bracket for boiler model 1200

- The horizontal brackets (L-brackets) comprise of two components, which must be pre-assembled. Join both bracket components with two bolts and two nuts (Fig. 11).
- Hook the first bracket (Fig. 12, **Item. 1**) with the U-shaped edge into the respective recess of the front, center and rear cross brackets.
- The bracket is secured at the front hole and the rear slot using one self-tapping screw each (Fig. 12).
- Hook the second bracket (Fig. 12, **Item. 3**) with the U-shaped edge into the respective recess of the front, centre and rear cross brackets.
- The bracket is secured at the front hole and the rear slot using one self-tapping screw each (Fig. 12).
- Align the central cross bracket horizontally.

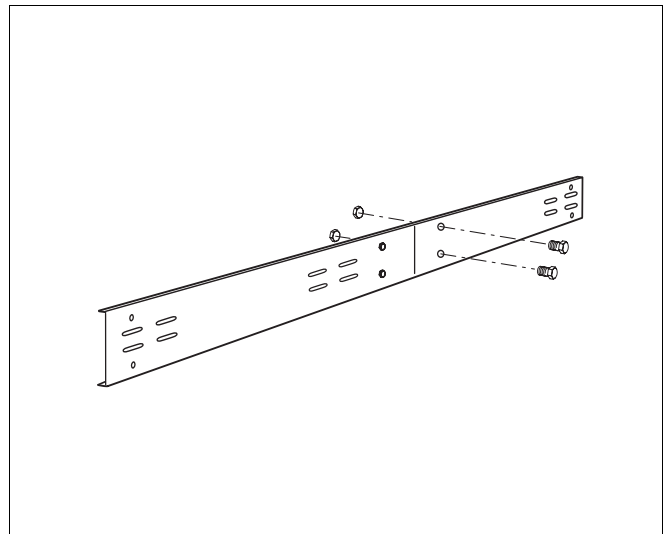

Fig. 11 Longitudinal (L-)bracket

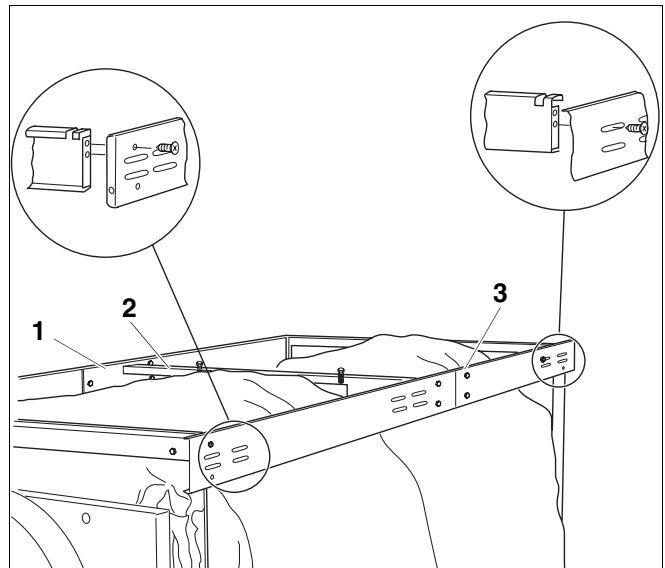

Fig. 12 Secure the longitudinal bracket with bolts supplied

- Item. 1: Horizontal bracket*
- Item. 2: Central cross bracket*
- Item. 3: Horizontal bracket*

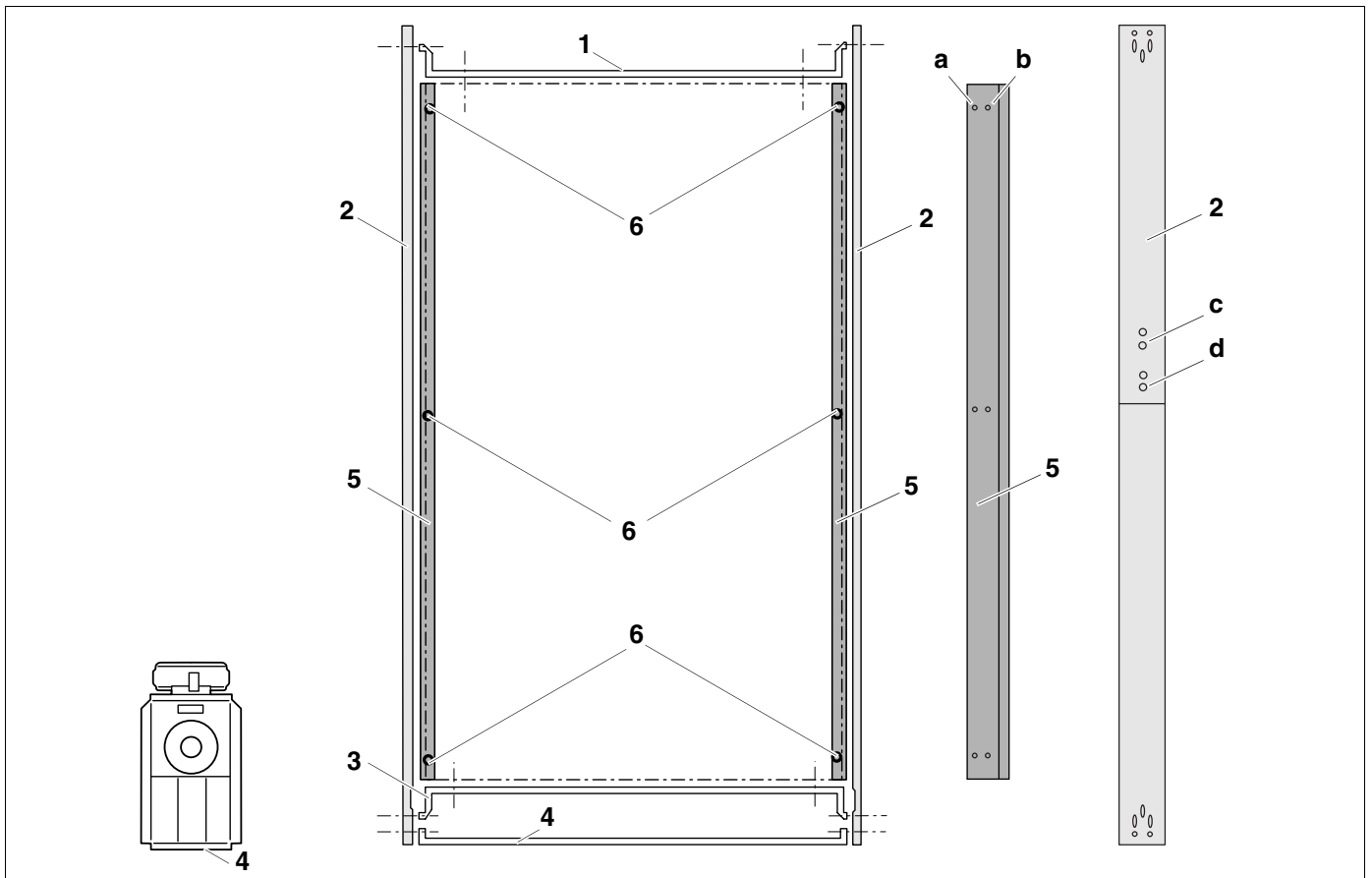

Fig. 13 Bottom cross brackets (top view)

- Secure the lower front cross brackets (Fig. 13, **Item. 3**) to the boiler body using two bolts.
- Secure the lower rear cross bracket (Fig. 13, **Item. 1**) to the boiler body using two bolts.
- Secure the left and right spacer plates (Fig. 13, **Item. 5**) to the lower cross bracket using three bolts and washers each (Fig. 13, **Item. 6**). Use the holes **Item. a** for boiler models 790 and 970. Use the holes **Item. b** for boiler model 1200.
- The lateral blue covers (Fig. 13, **Item. 2**) comprise two components, which must be pre-assembled (Fig. 13, **Item. c**: screw position for model 790 and **Item. d**: screw position for models 970 and 1200).

Hook-in both covers centrally behind the bracket and align horizontally, then join both pieces with two bolts.

- Secure the left and right side of the cover (Fig. 13, **Item. 2**) to the front and rear using one bolt each.
- Secure the blue cover (Fig. 13, **Item. 4**) at the left and right front of the cover (Fig. 13, **Item. 2**) using two bolts respectively.

- Item. 1: Rear cross bracket*
- Item. 2: Lateral covers*
- Item. 3: Front cross bracket*
- Item. 4: Front cross bracket cover*
- Item. 5: Spacer plate*
- Item. 6: Position of bolts on the spacer plate for boiler models 790 and 970 and 1200 (top view)*
- Pos. a: Position of bolts on the spacer plate for boiler models 790 and 970 (top view)*
- Pos. b: Position of bolts on the spacer plate for boiler model 1200 (top view)*
- Pos. c: Position of the bolts on the lateral blue covers for boiler models 790 and 970 (side view)*
- Pos. d: Position of the bolts on the lateral blue covers for boiler model 1200 (side view)*

- Hook the rear and central side walls at the bottom into the edge between the cover and the spacer plate (Fig. 14).

**NOTICE!**

Note the recesses (Fig. 14, **Item. 1**) in the side walls:

- Rear side wall 1 recess (towards the central side wall).
  - Central side wall 2 recesses.
  - Side wall nearest the front 1 recess (towards the central side wall).
- Lift the side walls and hook the top into edge of the horizontal brackets (Fig. 15).
  - Push the side walls back.
  - Push the ends of the insulation blankets behind the side wall edge.
  - Insert the small side sections (Fig. 15, **Item. 3**) into the side and at the bottom.
  - Secure the side wall nearest the front to the central cross brackets using one self-tapping screw (Fig. 15, **Item. 2**) and secure the central cross bracket.
  - Secure the small side sections (Fig. 15, **Item. 3**) at the front using two self-tapping screws each (Fig. 15, **Item.1**).
  - Align the side wall position with bolts Fig. 12.

**NOTICE!**

Remove the smaller side sections before opening the lower reversing door.

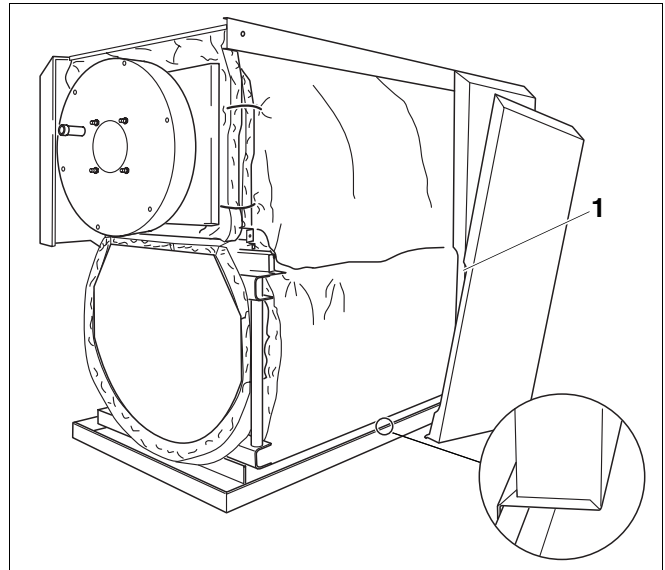

Fig. 14 Hooking in the side walls at the bottom

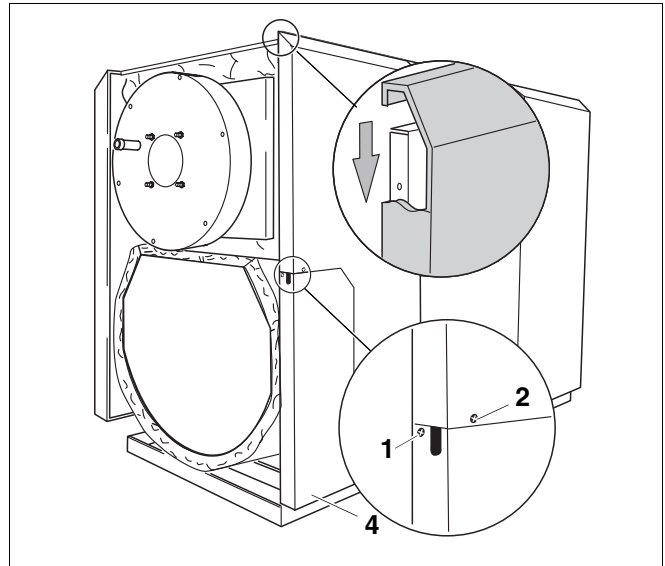

Fig. 15 Hooking in the side walls at the top

*Item. 1:* Self-tapping screw for the small side section

*Item. 2:* Self-tapping screw for the side wall nearest the front

*Item. 3:* Smaller side section

### 6.3 Boiler Jacket - Pack B

- Position the front boiler cover (Fig. 16, **Item. 1**) on top of the side wall edge and pull forward, until the left and right hooks lock into the slots.
- Secure the front boiler cover by means of two self-tapping screws (Fig. 16, **Item. 2**), which should be inserted through the boiler cover brackets and the side wall edge into the horizontal bracket.

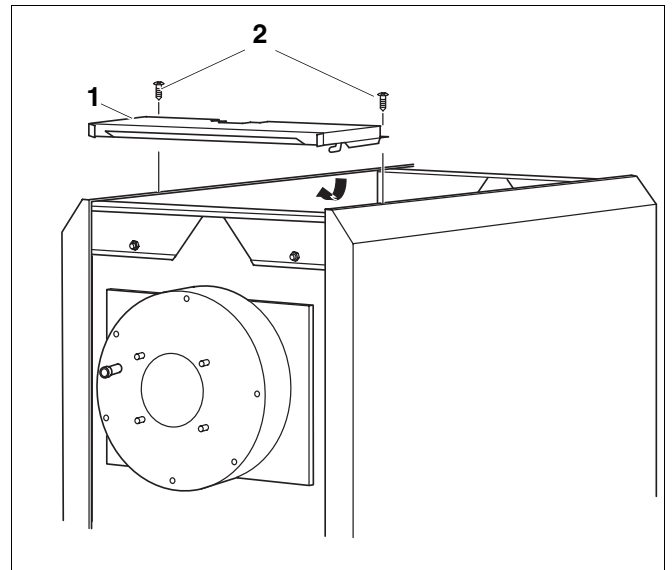

Fig. 16 Install the boiler front cover

## 6.4 Installation of the Control Panel and Sensor Well

The optional Buderus control panel „Logamatic“ is secured by fixing two hooks into the two holes in the front top cover.

### Control panel „Logamatic“ 2000 series

- Unscrew both self-tapping screws from the top out of the terminal cover and remove the cover (Fig. 17).
- Route the capillary tubes through the cable raceway and unroll to the required length.
- Locate the control panel so that the insert hooks are inserted at the front into the oval holes, pull the control panel forward and then tilt it back, until both resilient hooks snap into place on the right and left side (arrows Fig. 17).
- Secure the control panel to the front top cover on left and right inside in the cable raceway using two self-tapping screws.



#### NOTICE!

If necessary, break or cut out the knock-out from the rear wall of the control panel (Fig. 18).

Make all electrical connections in accordance with the wiring diagram and local code requirements.

- Insert cable clips into the clip frame and secure by pivoting the lever (Fig. 18).
- Insert both lower hooks on the right and the left side of the rear wall section into the clip frame, keeping the slot in the upper edge (Fig. 18).
- Press both upper resilient sliding hooks slightly inwards (arrows on Fig. 18) and insert the rear wall section so that both hooks lock into place.
- Locate the terminal cover and re-fit using the self-tapping screws (Fig. 17).



#### NOTICE!

Pay particular attention to the cable and capillary runs! Do not kink the capillaries. Connect the appliance with a permanent main electrical disconnect! Observe the local code requirements!

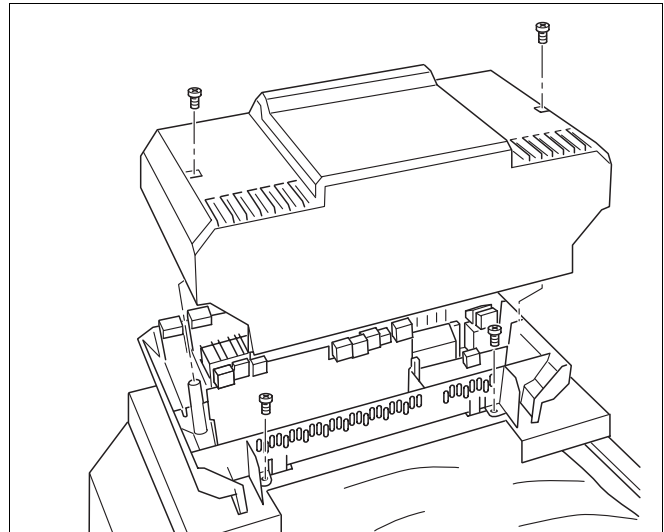

Fig. 17 Install the control panel

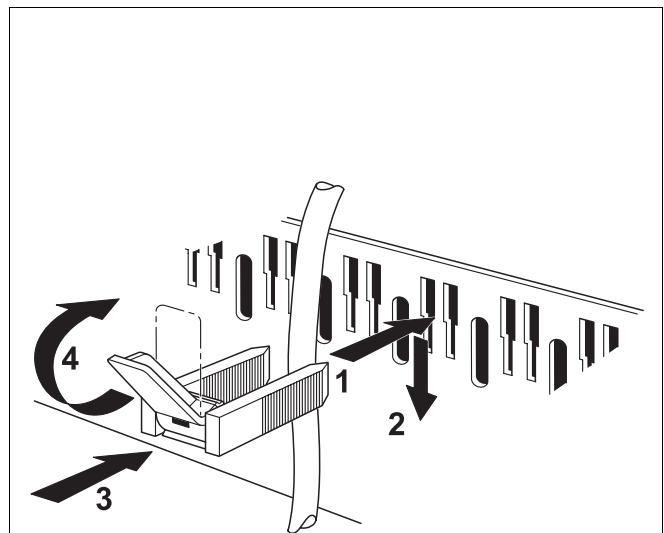

Fig. 18 Installation of the cable clips



- Install the well provided with the Logamatic control into the **M** tapping.
- Route the capillary tubes with sensor to the sensor well (Fig. 19).
- Insert the sensor into the sensor well, until it bottoms out (sensor well **M**, see page 6 in Fig. 1) (Fig. 19).

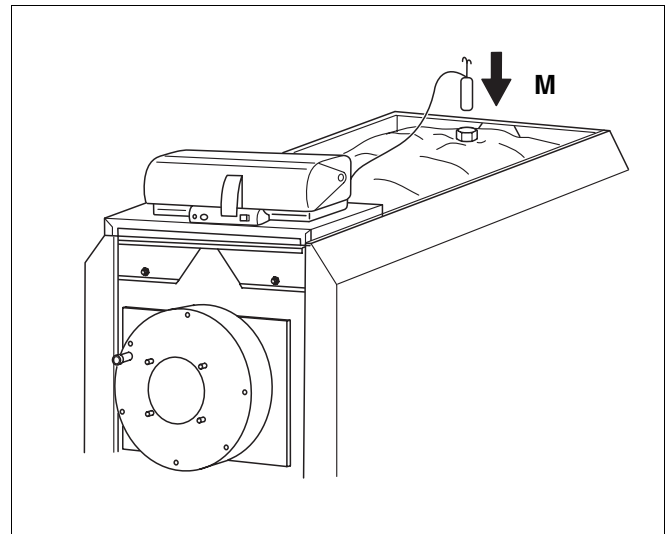

Fig. 19 Sensor to the sensor well

- During the insertion, the plastic spiral (Fig. 20, **Item. 2**) holding the sensor together slides back automatically. To ensure a perfect contact between the sensor well (Fig. 20, **Item. 3**) and the sensor surfaces - thereby guaranteeing the safe temperature transfer - push the compensating spring (Fig. 20, **Item. 1**).
- Push the sensor holder (Fig. 20, **Item. 4**) from the side or from above over the sensor well head.

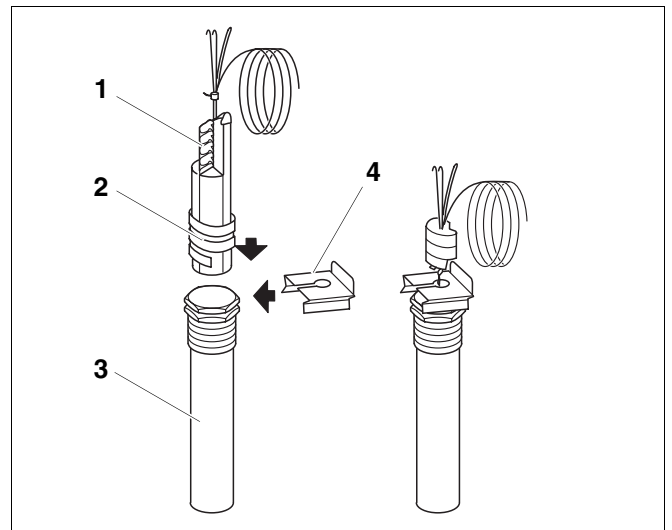

Fig. 20 Capillary tubes with sensor and sensor well

Item. 1: Compensating spring

Item. 2: Plastic spiral

Item. 3: Sensor well

Item. 4: Sensor holder

### 6.5 Burner Door and Burner

The burner door can be installed to swing to the left or right.



**DANGER!**

through falling parts.

Change the door opening only when the door is closed and bolted.



**NOTICE!**

The recesses (Fig. 21, **Item. 2**) in the boiler door (2 left and 2 right) have been provided for lifting with a crane or hoist, for example for the complete removal of the door.

- Push the hinge bolts (Fig. 21, **Item. 1**) out from the bottom through the top.
- Insert both hinge bolts with washers on the opposite side (Fig. 21).

**Do not forget to use the washers!**

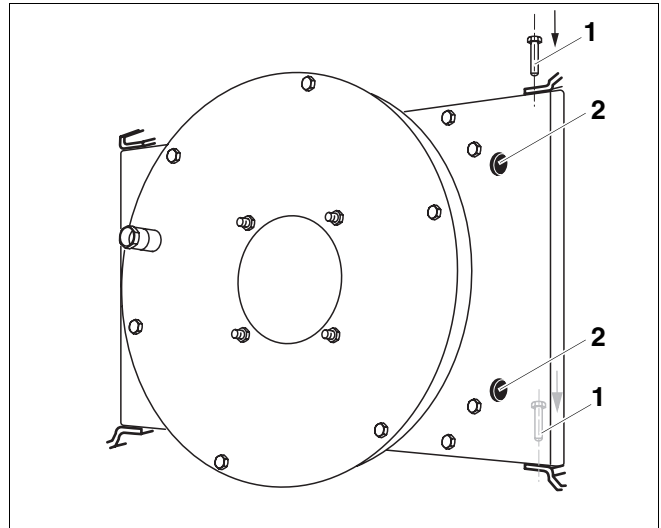

Fig. 21 Burner door

Observe the burner manufacturer's installation instructions!

Use or modify (drilled burner plate - accessory) the appropriate burner plate subject to burner make and type.



**NOTIVCE!**

Seal the gap between the blast tube (Fig. 22, **Item. 2**) and the thermal insulation (Fig. 22, **Item. 1**) on site using the insulation rings supplied (Fig. 22, **Item. 3**)! Cut insulation rings to required dimensions.

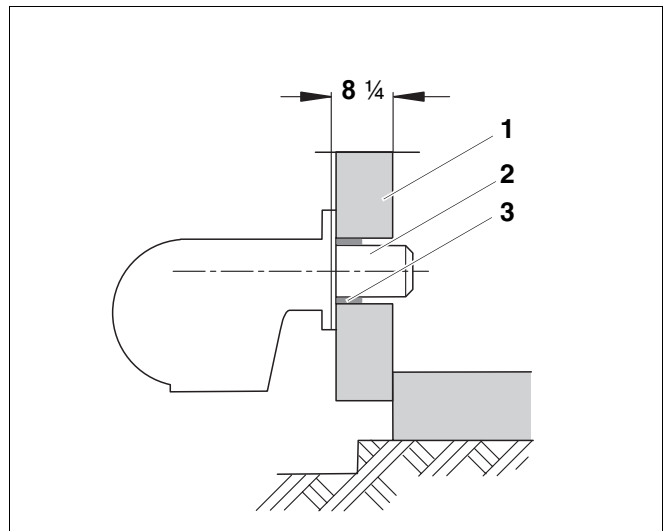

Fig. 22 Burner installation

*Item. 1: Thermal insualtion*

*Item. 2: Blast tube*

*Item. 3: Insulation rings*

## 6.6 Boiler Jacket - Top Covers

- Locate the boiler top cover sections Fig. 23 with the edges facing forward loosely onto the left and right side walls.
- Push the boiler top cover sections forward.



**NOTICE!**

The third top cover section provides a cut-out (Fig. 23, **Item. 3**) for the low water indicator. Cover the cut-out with a cover plate.

Boiler model	Item 1	Item 2	Item 3	Item 4	Item 5
790	17¾	17¾	17¾	11¼	11¼
970	17¾	17¾ </td <td>17¾</td> <td>19½</td> <td>19½</td>	17¾	19½	19½
1200	17¾	17¾	17¾	19½	19½

Table 5 Dimensions of boiler top cover sections from Fig. 23, Item. 1 to 5 (all dimensions in inches)

- Align and tightly secure the cross bracket.
- Insert the thermal insulation into the lower front wall (Fig. 24, **Item. 1**).
- Hook the lower front wall with four offset hooks onto the slots of the side wall edge (Fig. 24).
- Hook the offset brackets of the top front wall (Fig. 24, **Item. 2**) into the slots of the lower front wall edge and at the top into edge of the front top cover.



**NOTICE!**

If the front wall can only be located with some difficulties, re-align the central cross bracket.

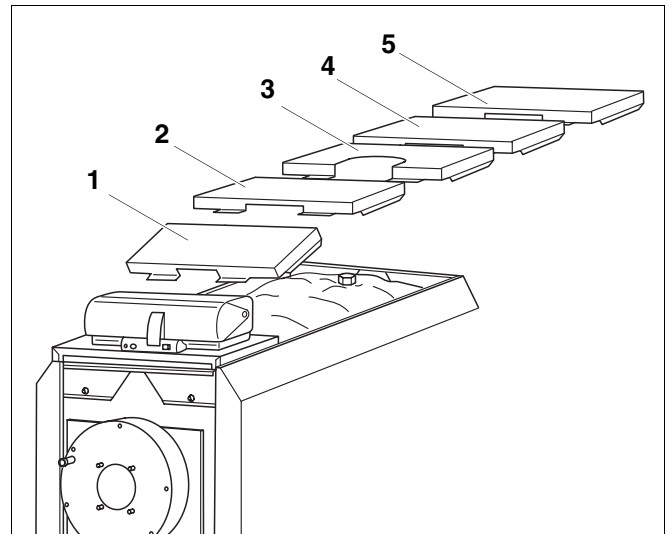

Fig. 23 Top cover sections

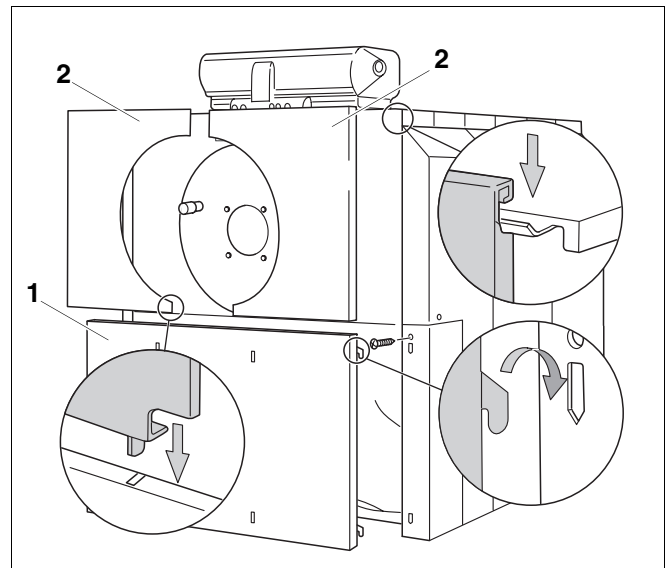

Fig. 24 Front cover panels

- Hook the upper (Fig. 25, **Item. 3**) and the lower cover part (Fig. 25, **Item. 2**) into the front wall sections using the hook provided.
- Secure the rating tag plate to the side panel (Fig. 25).

## 6.7 Rating Tag Plate

- Affix the rating tag plate (Fig. 25, **Item. 1**) according to the boiler location on the left or right side wall.

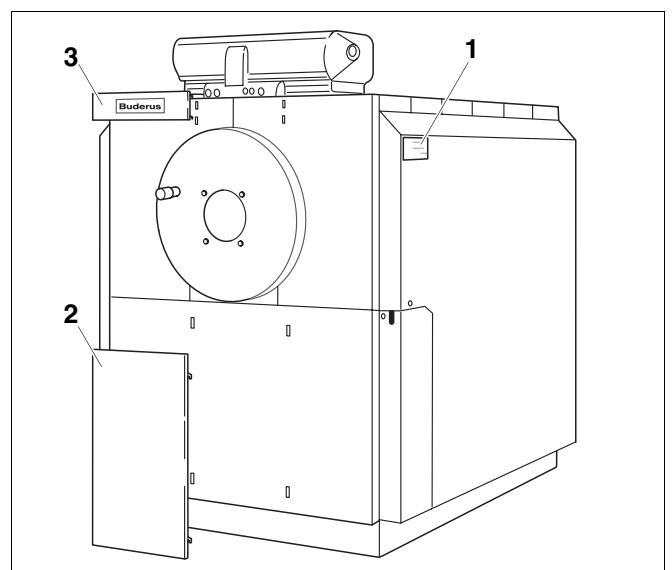

Fig. 25 Inserting front cover panels

### 6.8 Boiler Jacket - Pack C



#### NOTICE!

The rear wall consists of seven parts (Fig. 26).

- Secure the rear wall section (Fig. 26, **Item. 1**) with two self-tapping screws per side (left and right) on the side wall edges.
- Secure the small central rear wall section (Fig. 26, **Item. 6**) on the lower rear wall section (edge pointing inwards) using two self-tapping screws (Fig. 26, **Item. 1**).
- Locate the central rear wall section (Fig. 26, **Item. 2**) with the Z-profile behind the lower rear wall section on the edge of the side wall and secure on the left and right side with two self-tapping screws each.
- Insert the upper rear wall section (Fig. 26, **Item. 3**) with Z-profile behind the central rear wall section on the edge of the side wall, and secure on the left and right side with two self-tapping screws each.
- Hook the upper small rear wall section (Fig. 26, **Item. 4**) with the bracket into the upper rear wall section, and secure with a self-tapping screw.
- Secure one or two cable clips (Fig. 26, **Item. 5**) or a cable duct on the upper rear wall section.
- Secure the left and right locking plate (Fig. 26, **Item. 7**) on the side wall using two self-tapping screws respectively.

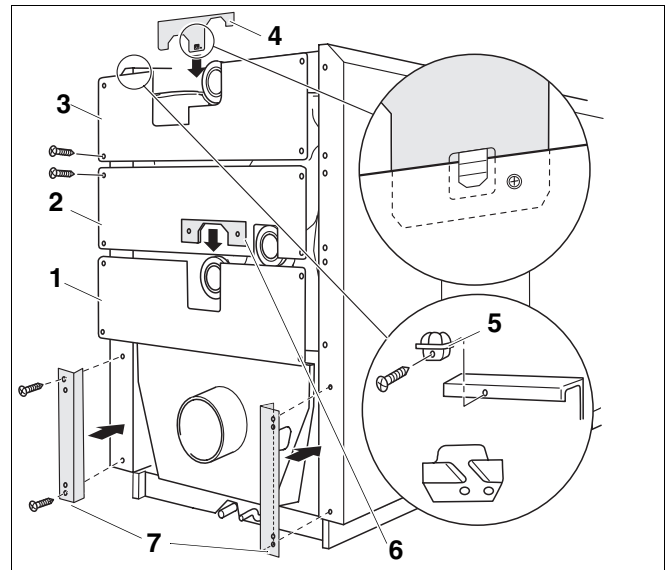

Fig. 26 installation of the rear wall section

- Item. 1: Lower rear wall section*  
*Item. 2: Central rear wall section*  
*Item. 3: Upper rear wall section*  
*Item. 4: Upper small rear wall section*  
*Item. 5: Cable clip*  
*Item. 6: Central small rear wall section*  
*Item. 7: Left and right locking plate*

## 6.9 Venting System

- The resulting combustion products must be transported through a chimney system to the outside.
- It is required to use venting systems approved for use with condensing, gas-fired equipment.
- Prior to placing the boiler in operation, it is required to verify compatibility between boiler and venting system.
- Check the venting system for air tightness!
- Install the venting system per manufacturer's instructions.

### SB Boiler Venting Requirements

The SB Boiler is a category II or IV appliance and the exhaust vent materials must be UL listed for use with a category IV appliance: operating temperatures of up to 240° F, positive pressure, condensing flue gas service. Currently, UL Listed vents of AL29-4C or 316L Stainless steel and/or CPVC must be used with the SB Boiler. Proper clearances to combustibles must be maintained per UL and vent manufacturer.

UL, NFPA 211 and NFPA 54 (National Flue Gas Code ANSI Z223.1) guidelines are often the basis for state and local codes. Buderus Hydronic Systems recommendations follow the guidelines of these recognized agencies unless there are codes applicable to the installation site that are more stringent. The venting and combustion air systems must meet all applicable code requirements.

### Code Required Vent Terminations:

#### Horizontal Terminations:

- Vent terminations should be at least 4 feet below, 1 foot above or 4 feet horizontally from any window, door or gravity air inlet of a building.
- The termination shall be at least 3 feet away from any other building opening, gas utility meter, service regulator or the like.
- The termination shall be at least 6 feet away from the combustion air intake of any other appliance.
- The bottom of the vent terminal should be at least 12 inches above both finished grade and any snow accumulation point.
- Vent should not terminate over public walkways or over an area where condensate or vapor could create a nuisance or be detrimental to the operation of regulators, meters and other equipment.
- Discharges should not be in wind-blocked areas, corners, or directly behind vegetation.

#### Vertical Terminations:

- Roof penetrations should follow all applicable codes and the vent manufacturer's instructions. The vent should never be installed at less than the required clearances to combustible materials per UL, NFPA, and local codes. "Double-wall or thimble" assemblies are required when penetrating combustible walls and roofs.
- Vertical discharges should extend at least 2 feet above the roof through properly flashed penetrations and at least 2 feet above anything within a 10 foot horizontal diameter. Discharges that extend more than 2 feet above the roof must be laterally supported.
- If the vent system is to be connected to an existing stack, the stack must be UL Listed for Category II or IV appliances (capable of 240°F, positive pressure and condensing flue gas operation).
- Masonry stacks must be lined and the vent penetration must terminate flush with and be sealed to this liner. Vents may enter the stack through the bottom or side.
- SB Boilers vent systems must not be interconnected to any other venting system; The SB Boiler is designed to maintain its own vent system.
- The exhaust vent must be pitched up toward the termination a minimum of ¼" in. per foot of length. Condensate must flow back to the SB Boiler freely, without accumulating in the vent.

### Combustion Air from Outside the Building

If outside combustion air is required, the room shall have two permanent louvered openings to the outdoors. Each opening must have a minimum free area of 1 square inch for each 4,000 Btu/hr of total input rating of all fuel burning equipment in the space.

When the air is supplied to the room via ducts, two ducts must be used. Vertical ducts and openings must have a minimum free area of 1 square inch for each 4,000 Btu/hr of the total input rating of all fuel burning equipment in the space. Horizontal ducts and openings must have a minimum free area of 1 square inch for each 2,000 Btu/hr of the total input rating of all fuel burning equipment in the space.

The free area of the openings must be taken into account restrictions from the louvers and screens. The louver manufacturer should be consulted for the percentage of free area available. When free area is not known, metal louvers typically have 60 - 70% of free area, wooden louvers have between 20 - 25% of free area. Louvers should be in a fixed position or interlocked with equipment so that they open automatically during equipment operation.

The combustion air damper opening shall be located as follows: top louver shall be located within 12" of the ceiling and the bottom louver within 12" of the floor as prescribed in NFPA 54.

### Combustion Air from an Adjacent Room

Where combustion air is to be used from within the building, air must be provided into the equipment room through two permanent openings into the interior building. Each opening must have a minimum free area of 1 square inch for each 1,000 Btuh of the total input rating of all fuel burning equipment in the space. The louvers shall be located as follows: top louver shall start within 12" of the ceiling and the bottom louver within 12" of the floor as prescribed in NFPA 54.

### Exhaust Vent Systems

**Positive-Pressure** - The vent system is designed to be under positive pressure at all firing rates. The minimum vent size is 14" diameter. Horizontal vent pipe should be supported at least every 6 feet and vertical vent should be supported to prevent excessive weight on the horizontal runs.



#### WARNING!

Use only an approved vent starter coupling and approved vent pipe from the same manufacturer for Buderus SB boilers. Do not mix components from different systems. The vent system could fail, causing flue gas spillage, resulting in severe personal injury or death.

### Permissible Equivalent Venting Length Configurations for SB735 Boilers

Permissible Equivalent Venting Length Configurations for SB735 Boilers (in ft)			
Model	Nom. Vent Size	12"	14"
790	14"	165	195
970	14"	130	180
1200	14"	-	165

Table 6 Maximum venting length for SB735 boilers



#### NOTICE!

Above lengths represent total equivalent vent length combining horizontal and vertical runs and any elbow. For each 45° elbow, deduct 4 ft, for each 90° elbow, deduct 7 ft.

A positive breeching draft is not to exceed positive + 0.2 Inches WC.

### Condensate Removal

The exhaust vent pipe must be pitched at least 1/4" per foot of length back to the boiler. This will allow condensate to drain back to the unit to be disposed. Low spots in the venting where condensate may collect should be avoided. A plastic hose or PVC drain pipe may be used to remove discharge to a floor drain. Care should be taken to avoid kinks and from raising the drain line above the trap assembly. If the condensate must be lifted above trap assembly to a drain, it should be drain into a sump so that it can pump away to a drain.

## 6.10 Neutralization Equipment and Water Controls Installation



### NOTICE

Observe the separate installation instructions for the installation and maintenance of the neutralization system (part of the standard delivery of the neutralisation system).

- Push the siphon delivered onto the pipe connector on the flue gas collector and tighten the union nut on the siphon.
- Connect the drain hose to the connector (Fig. 27, **Item. 1**) of the condensate drain (Siphon) (Fig. 27, **Item. 2**) using a hose clip. When using  $\varnothing 1\frac{1}{2}$ " pipe remove the tee piece on the siphon with a saw.



### NOTICE!

Generally, the condensate should be routed to the boiler via the flue pipe. Where this is impracticable, use only stainless steel or plastic tee pieces in the separate feed hose pipe.

- Secure furnished supply manifold and gasket to upper water connection (VK connection in (Fig. 1, page 6)).
- Install furnished relief valve in supply manifold and pipe discharge full port to nearby floor drain.
- Install low water cut-off and aquastat (s) in available  $\frac{3}{4}$ " manifold tapings.
- Install pressure and temperature gauge in  $\frac{1}{2}$ " tapping.
- Plug any unused tapings.
- Refer to section 6.4 when installing Logamatic control. Plug sensor port M (Fig. 1, page 6) with  $\frac{3}{4}$ " plug when **not** using a Logamatic control.



### NOTICE!

Lower return connection RK1 (Fig. 1, page 6) must **always** be used for connecting heating systems return. Connect coldest return zone(s) to RK1 for maximum efficiency. Connect higher temperature return zone(s) to RK2 (Fig. 1, page 6) if called for by engineering firm / design. If the RK2 connection is **not** used, close it off with a blanking flange.

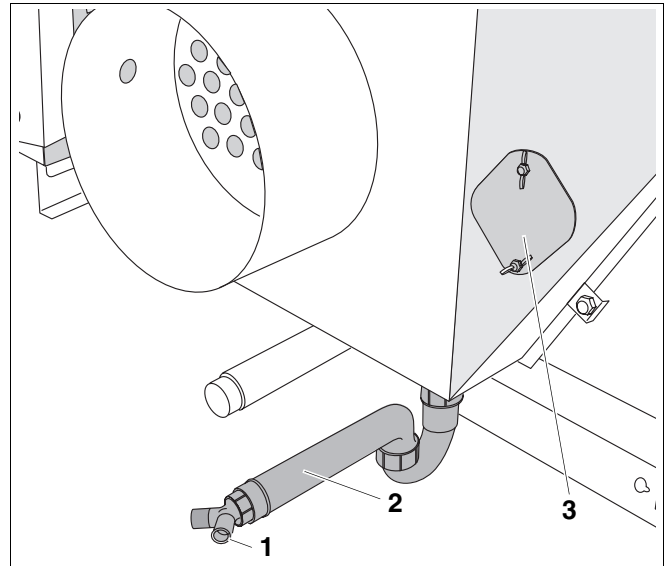

Fig. 27 Condensate

Item. 1: Connection for a drain hose

Item. 2: Siphon

Item. 3: Clean-out cover

## 7 Placing the Boiler in Operation

**DANGER!**

due to combustion products.

Prior to placing the boiler in operation, put 3 or 4 gallons of water in the clean-out opening or combustion chamber to fill the drain in the condensate drain line (Fig. 27, **Item. 3**).

**BOILER DAMAGE!**

due to corrosion and debris build-up.

Flush the entire heating system prior to firing the boiler. To avoid corrosion and debris build-up on the water side of the boiler. It is required to test the fill and make-up water per Instructions for Water Preparation for Boiler.

**NOTICE!**

Observe the installation instructions for the neutralization system!

Follow the instructions supplied with boiler, burner, controls and low water cut-off components during the start-up of the system.

Make the end user familiar with the function and operation of the entire system and sign over the technical documentation.

It is recommended to instruct the end user regarding maintenance requirements and procedures. An annual service contract is recommended.



## 8 Maintenance

### 8.1 General Information



**DANGER!**  
due to unauthorized service work.

Maintenance work on gas components can only be carried out by a gas certified service company.



**NOTICE!**  
The end user or operator is required to have regular scheduled maintenance performed. An annual maintenance procedure on the entire system is required.



**NOTICE!**  
We recommend an annual service contract for the maintenance.

The factory required maintenance steps are outlined in the check list (see section 9 „Check List“).

Follow the burner manufacturer's instructions regarding burner maintenance!

### 8.2 Cleaning of the Boiler



**DANGER!**  
due to incorrect boiler brushes.

Use only brushes made available through Buderus Hydronic System, Inc..



**DANGER!**  
due to current carrying wires.

Prior to maintenance shut down the electrical power supply and pad lock.



**NOTICE!**  
A high pressure washer is recommended for a wet cleaning of the heat exchanger.

Boiler debris should not be sent through the neutralization system.

Check to make sure the condensate drain does not get plugged (Fig. 27, Item. 2.).

- Check and possibly clean the flue gas collector and the condensate drain through the clean-out cover (Fig. 27, **Item. 3**).
- Remove the upper (Fig. 28, **Item. 4**) and lower cover part (Fig. 28, **Item. 1**).
- Remove the upper front wall (left and right) (Fig. 28, **Item. 3 und 5**).
- Remove the lower front wall (Fig. 28, **Item. 2**).
- Remove the left and right side wall sections (Fig. 28, **Item. 6**).

**DANGER!**

through falling parts.

Ensure that the hinge bolts (Fig. 29, **Item. 1 and 2**) are in the boiler door and in the reversing door, before opening the doors.

- Loosen the bolts on the reversing door (Fig. 29, **Item. 1**) and pivot the reversing door aside.
- Remove the hexagon bolts from the boiler door (Fig. 29, **Item. 2**) and open the door.
- Clean the combustion chamber and the heating surfaces.
- Brush out the secondary and third firetubes (Fig. 30).

**NOTICE!**

When cleaning the secondary and third firetubes, the entire brush head should protrude from the firetube before the cleaning brush is withdrawn again.

- Remove any cleaning residues with a vacuum cleaner. Observe the opening instructions of the cleaning equipment when cleaning by pressure spray!
- Check the gaskets on the boiler door and the reversing door and replace, if necessary.

**SYSTEM DAMAGE!**

Spray must not enter into the control panel!

- Close and bolt down the boiler door.
- Close and bolt down the reversing door.
- Fit the insulation blanket.
- Install the side wall sections.
- Install the upper and lower front wall.
- Re-start the system.

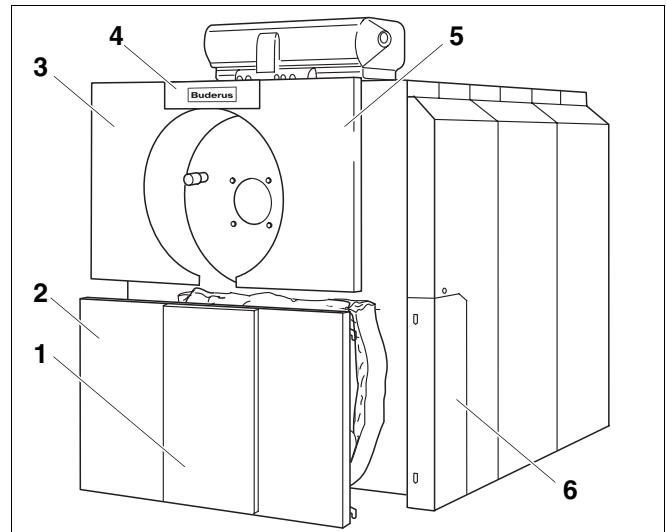

Fig. 28 Remove the front wall

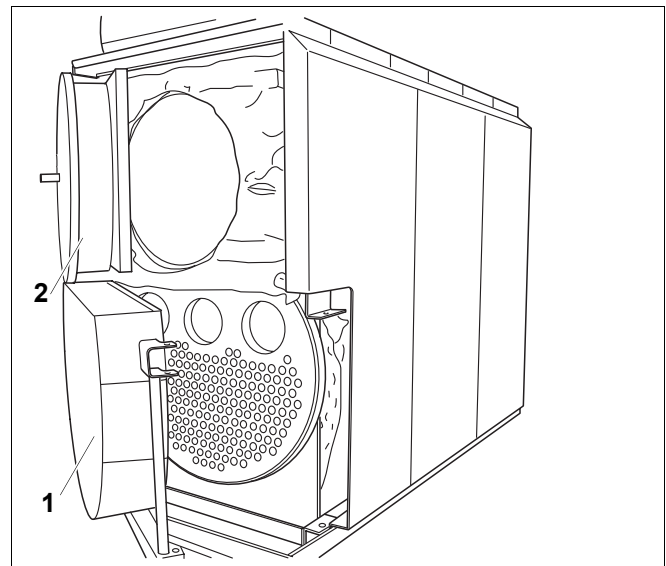

Fig. 29 Open the boiler door

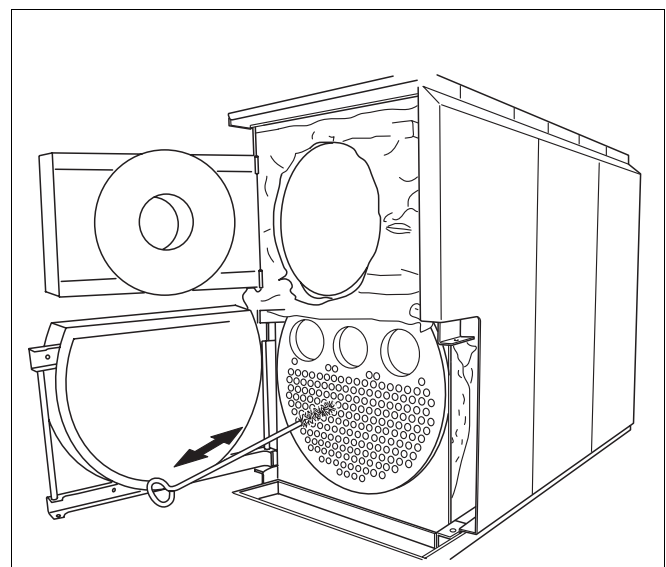

Fig. 30 Cleaning the secondary and third firetubes

## 9 Check List

Check off the different maintenance steps, place an „X” in the corresponding box and list date and service company name below.

Follow recommended time frame for boiler and burner maintenance work.

Heating system		01	02	03	04	05	06	07	08
1	Disconnect electrical supply to system								
2	Shut off gas supply								
3	Disconnect gas supply from burner								
4	Remove front jacket panels, open burner door								
5	Remove reversing door								
6	Remove condensate drain hose from neutralization system								
7	Check and clean combustion chamber								
8	Check and clean out fire tube passages								
9	Flush condensate drain connection at boiler								
10	Check and clean flue collector								
11	Check burner gasket, replace if necessary								
12	Check gasket on reversing door, replace if necessary								
13	Reattach condensate drain hose								
14	Close off the reversing cover, bolt down and assemble jacket panels								
15	Pour 3 gal. of water into the combustion chamber								
16	Close the burner door, bolt down and assemble jacket panels								
17	Reattach the gasline to the burner								
18	Check the gasline for leaks and correct if necessary								
19	Check venting system for leaks, repair when needed								
20	Check operation of the safety controls								
21	Check operation of all operating controls								
22	Bring the system back into regular operation								
23									

Neutralization system		01	02	03	04	05	06	07	08
1	Isolate the neutralization system from the main electricity supply								
2	Disconnect the inlet and outlet hose from the granulate container								
3	Remove the container lid of the neutralization system								
4	Remove used granulate (the container can be filled by 180°), clean out the container								
5	Fill with fresh granulate (in accordance with instructions)								
6	Replace and, if necessary, bolt down the container lid of the neutralization system								
7	Plug-in the mains cable of the neutralization system into a main socket								
8	Reconnect all hose connections and check for leaks								
9	Start-up the neutralization system								
10									

Specialist contractor _____ <b>01</b> Date:	Specialist contractor _____ <b>02</b> Date:	Specialist contractor _____ <b>03</b> Date:	Specialist contractor _____ <b>04</b> Date:
Specialist contractor _____ <b>05</b> Date:	Specialist contractor _____ <b>06</b> Date:	Specialist contractor _____ <b>07</b> Date:	Specialist contractor _____ <b>08</b> Date:







BBT North America Corporation  
50 Wentworth Avenue  
Londonderry, NH 03053  
Tel. 603-552-1100  
Fax 603-584-1681  
[www.buderus.net](http://www.buderus.net)

Products manufactured by  
BBT Thermotechnik GmbH  
D-35573 Wetzlar  
[www.buderus.de](http://www.buderus.de)

BBT North America Corporation reserves the right  
to make changes without notice due to continuing  
engineering and technological advances.

**Buderus**